

free
selva

wall
selva

sky
selva

selva

acoustic collection





enjoy the **silence**



design: **Ronald Straubel**

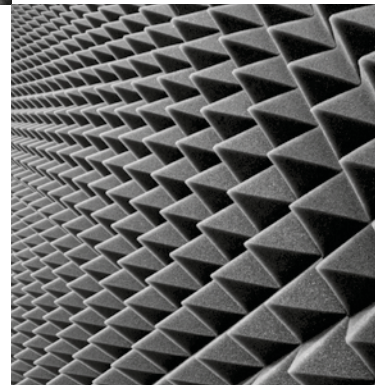

selva collection

A complete system

Selva means three types of products: free-standing screens, wall-mounted panels and ceiling-mounted panels. All elements complement each other, bringing positive vibes to a given interior and its acoustics.

Scientific approach

More than two years of research at laboratories of scientific centres (including the Laboratory of Technical Acoustics at the AGH UST Department of Mechanics and Vibroacoustic in Cracow and laboratories of the Faculty of Wood Technology at Poznan University of Life Sciences) allowed for precise selection of materials and the optimal acoustic arrangement, the efficiency of which has been confirmed by appropriate certificates.

Design

The interesting shape of the panels, wide colour range of fabrics and modern design of the bases all contribute to the fact that your office will acquire not only extraordinary acoustic qualities but also the look of a friendly and modern place.

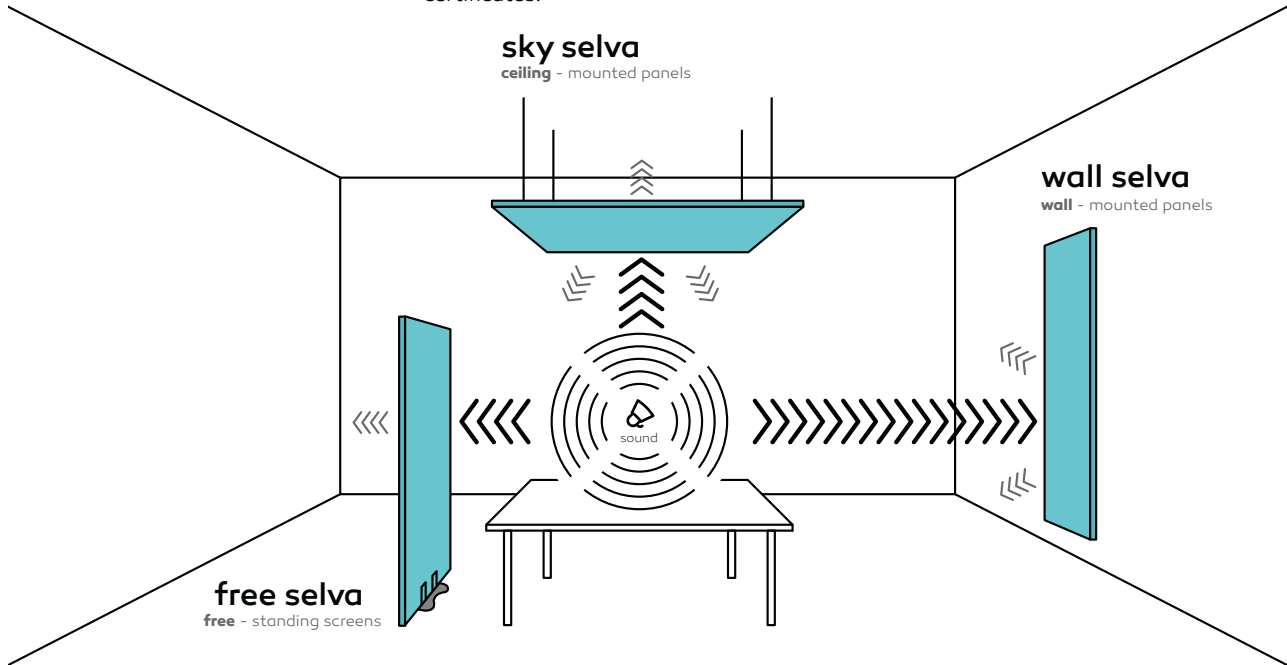

IN HARMONY WITH NATURE.



Materials used in manufacturing of selva collection are natural and biodegradable, thus environmentally friendly.





PASSIVE
acoustic



4

SVSC8T

ACOUSTICS IN PRACTICE.

All conversations taking place in a given room together with devices working in it create sound waves. They spread throughout the room in all directions, starting from the sound source. These waves have certain energy, some of which bounces or gets diffused while some is absorbed or penetrates to the other side of a given material.

Open space is an architectural solution that is increasingly often utilised, but not the best as far as acoustics is concerned. With Selva collection, you can improve the acoustics of a given room.

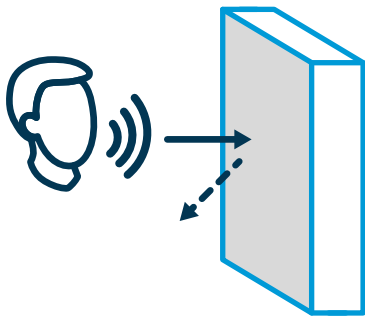

Bouncing

The sound bounces. The possibility of echo or unpleasant reverberation. Much of the noise can be eliminated with installation of selva wall panels.

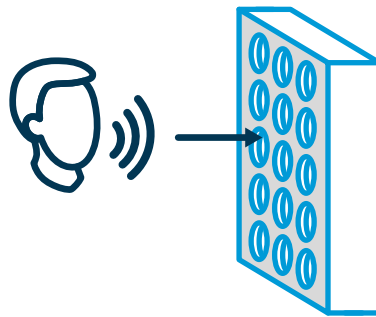

Absorption

The sound is eliminated, which reduces the reverberation. This is possible with a system of selva wall and sky panels and free selva screens.

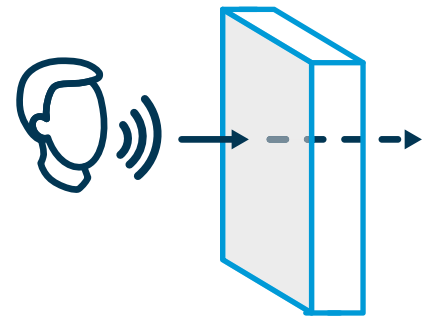

Penetration

The sounds comes through to the other side. The more sound is stopped by the selva free screen, the better control of the sound.



6

Various installation possibilities

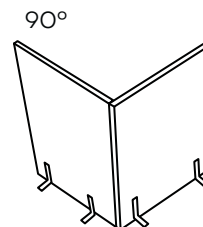
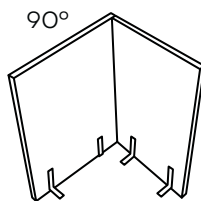
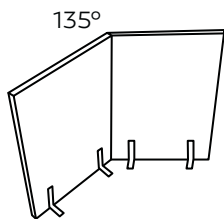
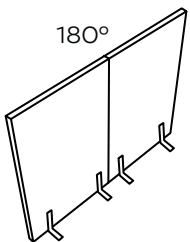



calm works ⁷

selva leaf

SVSC8T



SVSC8T



SVSC8T



selva free

Minimalist aesthetics, beautiful chrome bases and attention to quality of the finish are details - but they are crucial for the creation of calm and quiet atmosphere.



selva **cell**

SVSC8



SVSC12



Installation configurations for selva screens

180 degrees



135 degrees

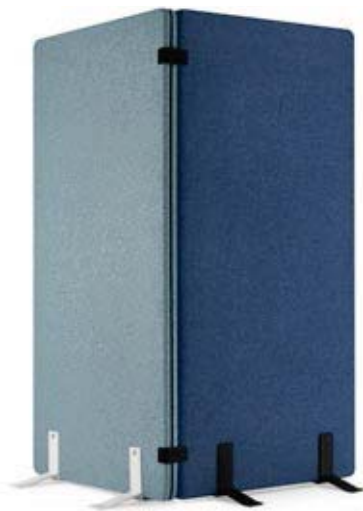

90 degrees



135 degrees

Bases

10



SV BC



SV BC 1



CD IN 135

selva free

90 degrees



CD IN 90

180 degrees



CD IN 180

180 degrees



CD OUT

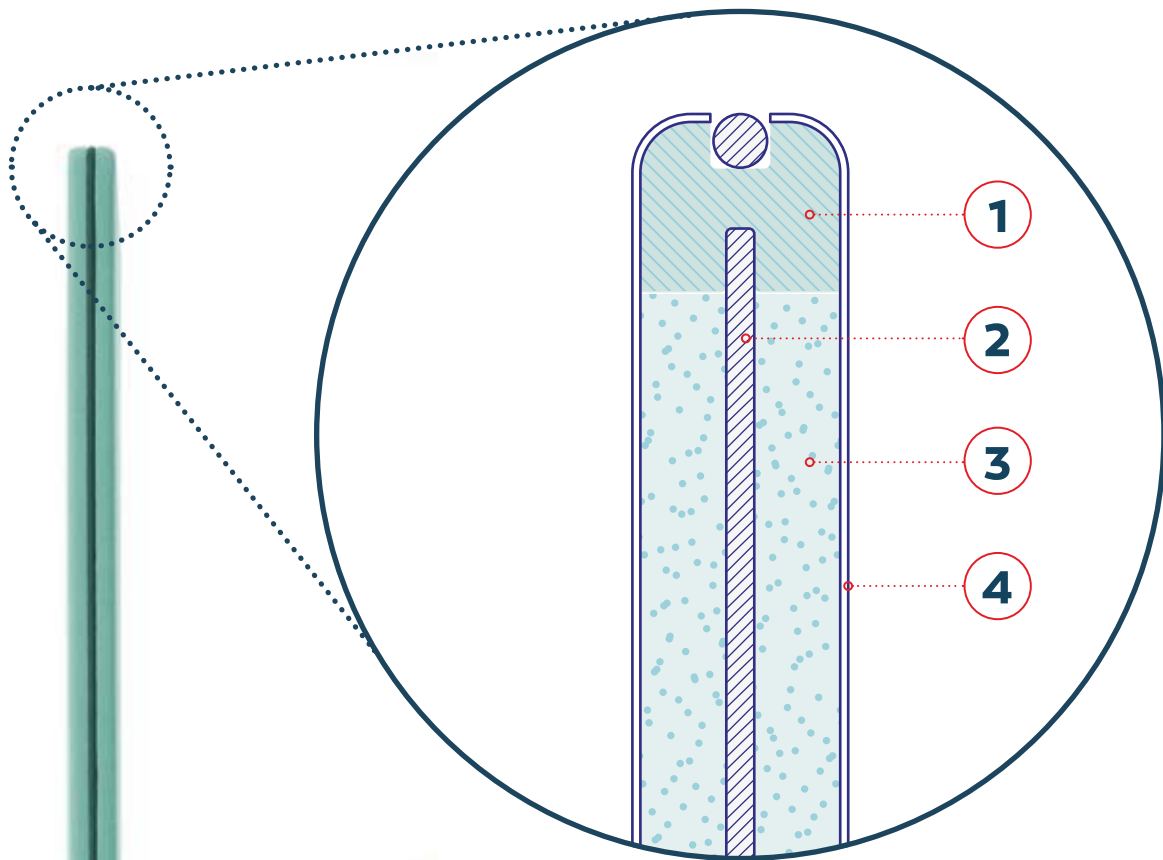

PATENTED CONSTRUCTION

- 1. **Pine framework** - stable construction
- 2. **Solid partition** - efficient soundproofing
- 3. **Unique fiber structure** - sound absorption
- 4. **Upholstery** - attractive look and better absorption



INNOVATIVE CONSTRUCTION SOLUTIONS.

Selva acoustic screens stem from long-term and thorough scientific research conducted in cooperation with academic centres. After analyses of acoustic characteristics of numerous materials and tests run with different configuration of those, a product has been created that fully optimises room acoustics. **With their patented structure of layers, Selva free-standing screens achieve better soundproofing and sound absorption parameters than standard solution available in the market.** The solid partition is an efficient soundproofing tool which diminishes its penetration to the other side, while the soft layer absorbs the sound to an even greater degree and improves the acoustic features of the room.



EXTRAORDINARY ACOUSTIC PARAMETERS OF THE SELVA COLLECTION.

The positive influence on room acoustics has been confirmed among others by tests of acoustic efficiency for office screens, run in accordance with the PN ISO 10053:2001 standard by the Laboratory of Technical Acoustics at the AGH UST Department of Mechanics and Vibroacoustic in Cracow.

Research proves that with utilisation of Selva acoustic screens, the average sound level decreases by 8 dB. The reduction is significant since the human ear subjectively feels as if the noise has been reduced by almost half.

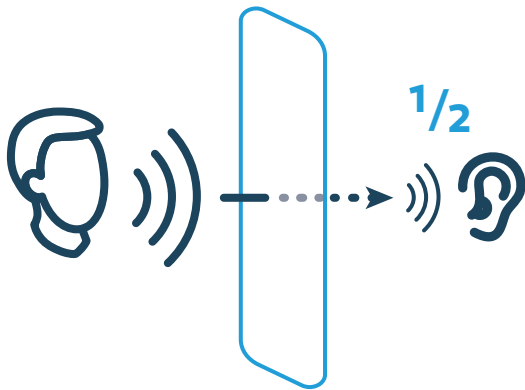

Reduction of noise by nearly half

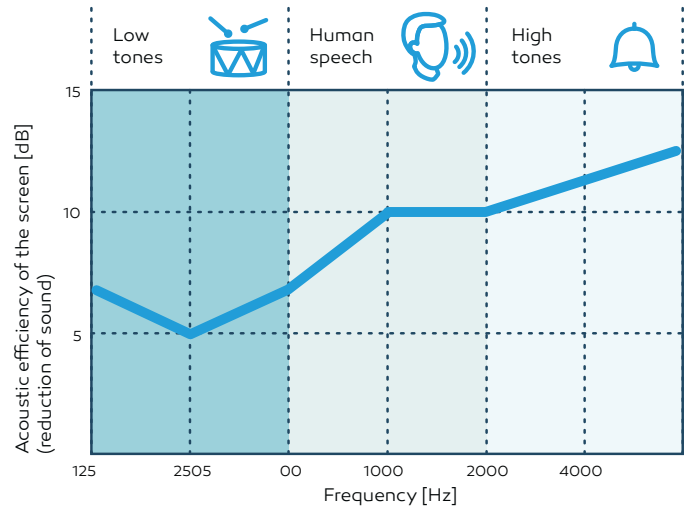

FREE ARRANGEMENT OF SPACE AND EASY INSTALLATION.

Selva acoustic screens can be used as separate elements or grouped in any configuration in a simple and quick way. This means easy arrangement of space within short time.





let's play with
shapes & colours

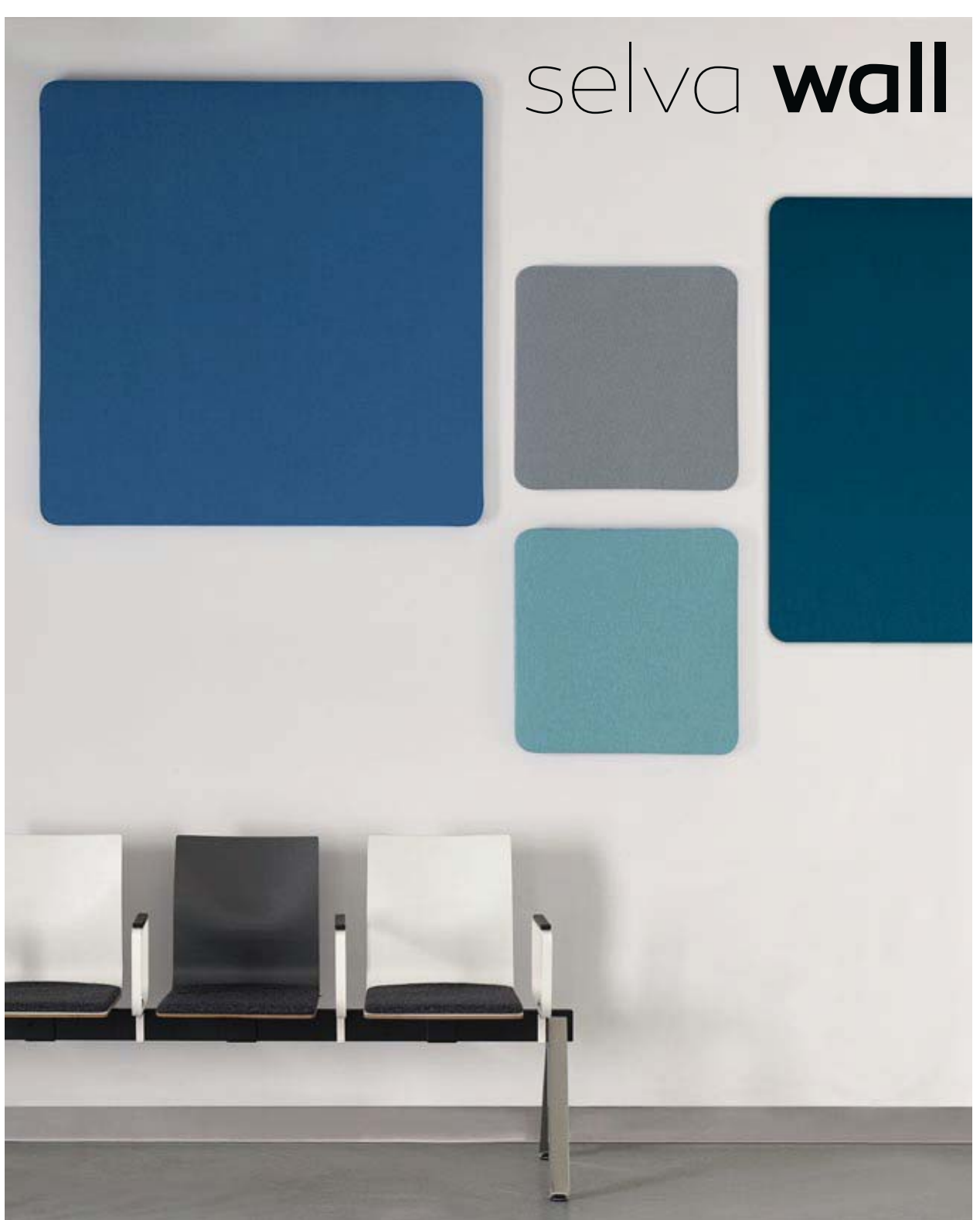

selva wall



SV PSC 6

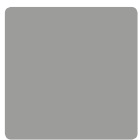

SV PSC 12



SV PSC D6

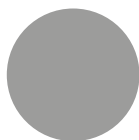

SV PSC D12



SV PSC 18



SV PSC 24

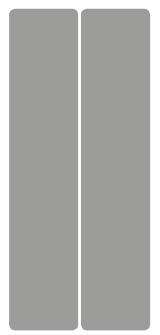

SV PSC 27



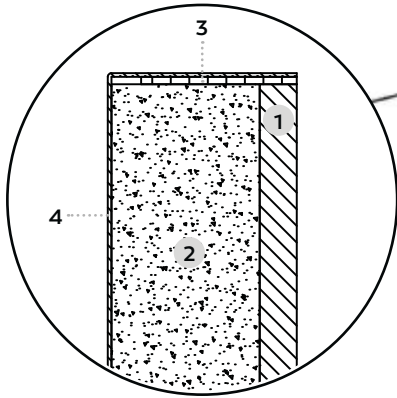
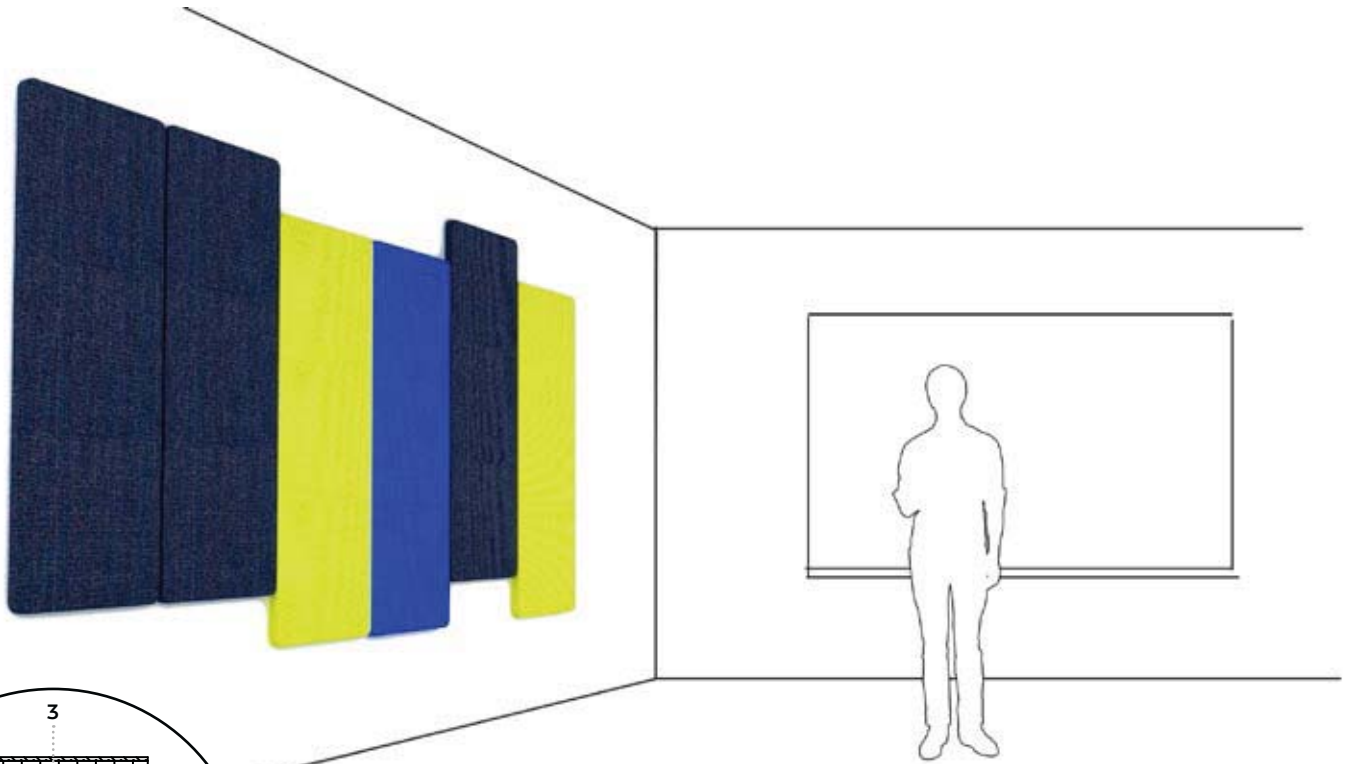

Construction of the panel:

1. Hard MDF board.
2. Unique fiber structure - efficient sound absorption.
3. Shape-providing profile and space for acoustic, non-woven fabric
4. Upholstery - selected fabrics enhancing the acoustic features of interior layers.

A cross-section of the Selva Wall acoustic panel



ABSORPTION CLASS A

According to international ISO 11654 standard, sound absorption level is ascribed to one of five absorption classes, marked with A to E letters. Our selva wall wall-mounted panels have been analysed with use of methodology of PN-EN ISO 354:2005 standard.

Selva panels have obtained the highest sound absorption class: A.

Sound absorption class:	α_w
A	0,9-1,00
B	0,8-0,85
C	0,6-0,75
D	0,3-0,55
E	0,15-0,25
not classified	0,00-0,10

SV WI





the perfect experience of quiet

19

Available models/shapes:



SELVA PANELS HAVE OBTAINED THE HIGHEST SOUND ABSORPTION CLASS: A.



SV P SF 8

SV P SF 12

SV P SF 16

SV P SF D12

CANDY BASES



CD IN 180 - middle base that allows to set up a screen or screens in a straight line. The base is powder coated according to Bejot colour card, or chromed.



CD IN 90 - middle base that allows to set up two perpendicular screens. The base is powder coated according to Bejot colour card, or chromed.



CD IN 135 - middle base that allows to set up two screens at obtuse angle. The base is powder coated according to Bejot colour card, or chromed.



CD OUT - outer and closing base. The base is powder coated according to Bejot colour card, or chromed.

Candy bases are not integral elements of Selva free screens. It is easy to change the configuration and arrangements of the screens.

BASIC BASES



SV BC - powder coated according to Bejot colour card.



SV BC 1 - base used for arrangement of systems at various angles. Powder coated according to Bejot colour card

NOTE

For the screen to stand, two BASIC bases must be mounted to a single screen.

BASIC bases are integral elements of Selva Free screens (they are fixed to the screens).

CONNECTORS



SV CP - connector preventing free-standing screens from drifting apart. Powder coated according to Bejot colour card.



SV LP - metal connector preventing free-standing screens from drifting apart. Installed at three possible angles: LP90, LP135 and LP180. Powder coated according to Bejot colour card.

INSTALLATION OF THE PANELS

CEILING-MOUNTED PANELS | SELVA SKY

FITTING ELEMENTS

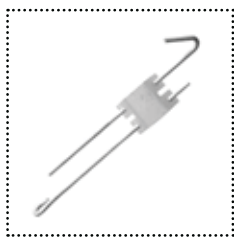

Hanger with a hook, regulated height: 100-300mm (SV WI 1030) or 300-600mm (SV WI 3060).



SV WI 4 - short hanger without height adjustment* (ca. 40mm).



SV LI 5015 - steel lines with fitting elements. Regulated height, 50-1500mm.



Panels can be hung at various heights.



20

- S standard equipment
- O optional equipment

Configurations of products other than presented here may differ as regards the sizes of screens and panels. The colours presented do not constitute an offer. The manufacturer reserves the right to introduce changes to construction and parameters of the products offered without changing their general character.

FITTING ELEMENTS



Mounting rails:

- a) panel-mounted (standard)
- b) wall-mounted (option)

The length of mounting rails depends on the shape and number of mounted panels

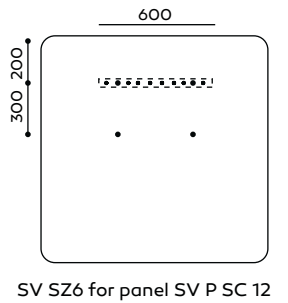
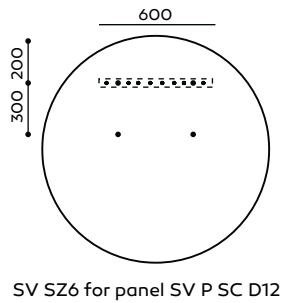
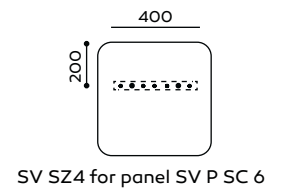
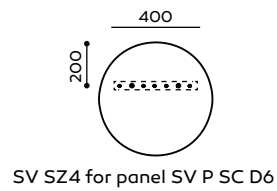
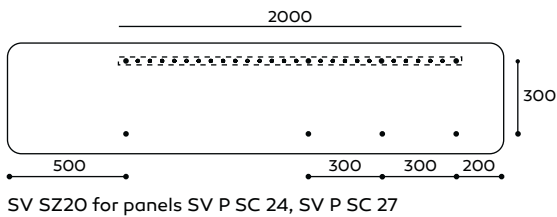
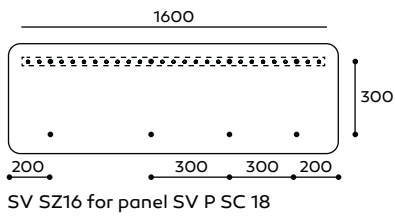
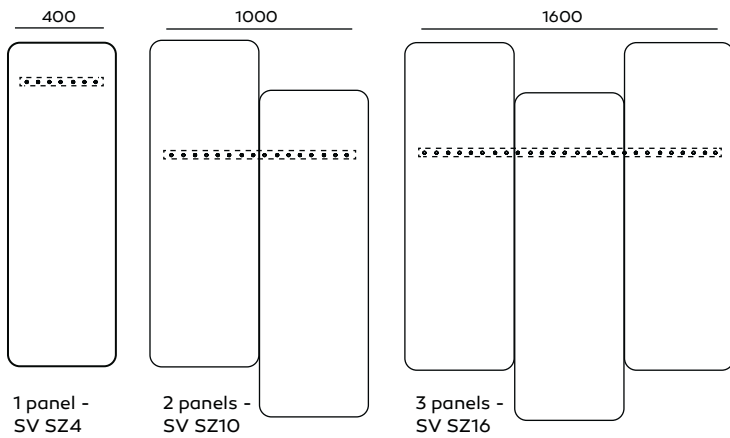

Example distance between holes for the mounting

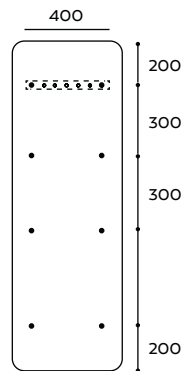

As a standard, a single mounting rail is attached to the panel at the highest possible level. To change the level, the rail should be moved to an appropriate place.

Possibility to install panels at various heights

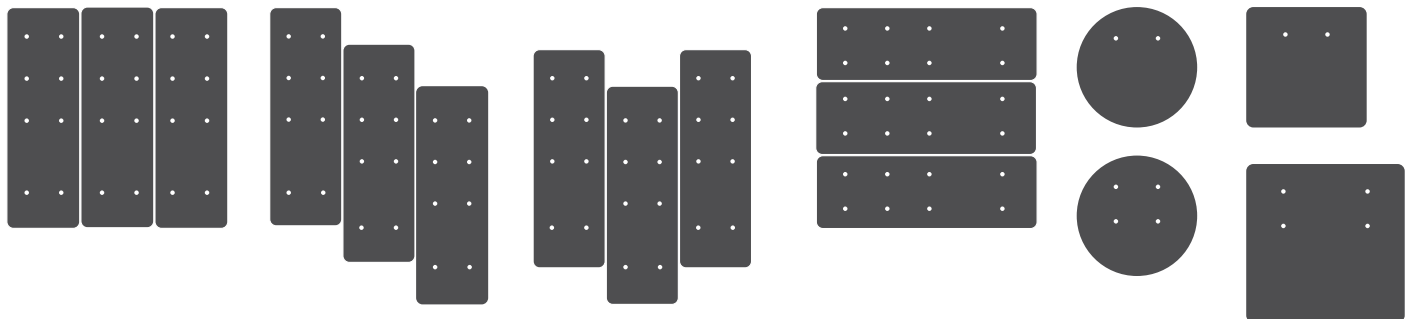

SELVA FREE

A SELVA CELL

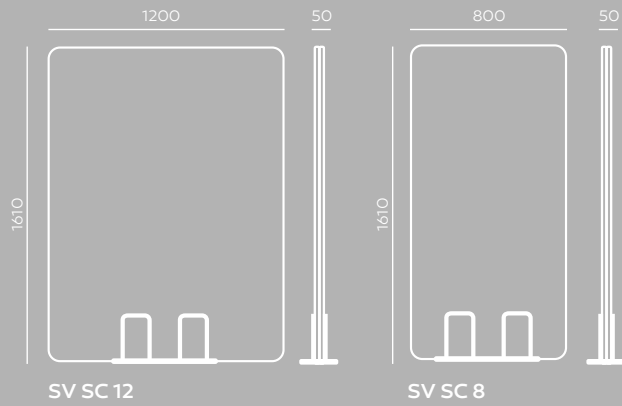

B SELVA LEAF

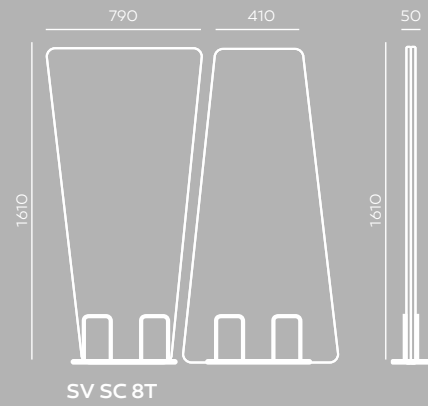

A CANDY



B BASIC

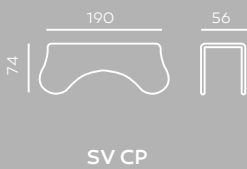
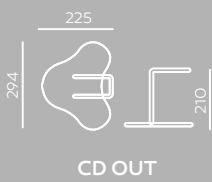
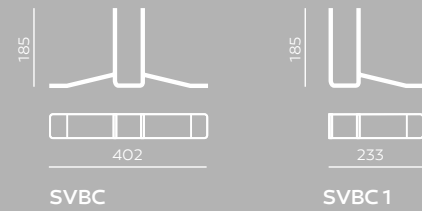



The mark of responsible forestry

ISO 14001



AC 070 EMS

ISO 9001



AC 070 QMS



Witteveen Projectinrichting
Ouderkerk a/d Amstel
Tel: 020 - 496 5030
info@witteveen.nl
www.scheidingswand.net
www.project-inrichting.nl



Fundusze Europejskie
Program Regionalny



**SAMORZĄD WOJEWÓDZTWA
WIELKOPOLSKIEGO**

Unia Europejska
Europejski Fundusz
Rozwoju Regionalnego

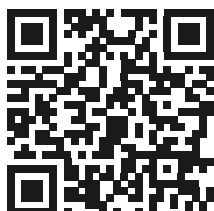

Bejot sp.zo.o., ul. Wybickiego 2A, Manieczki, 63-112 Brodnica n.Poznań, POLAND
Tel.: + 48 (61) 281 22 25, fax: + 48 (61) 281 22 54, e-mail: biuro@bejot.eu
www.bejot.eu

